

**BATTERY SWITCHES  
INSTALLATION AND OPERATING INSTRUCTIONS**

For use with alternators and generators rated 6-50 V.D.C.  
Switch rating: 315 amperes continuous, 450 amperes intermittent.

All wiring to the switch shall be performed by a QUALIFIED MARINE ELECTRICIAN, and in accordance with the "Fire Protection Standard For Motor Craft", N.F.P.A.\* No. 302, The Standards of the American Boat and Yacht Council, Inc.\*, and the U.S.C.G.\* Safety Standards for Boat Electrical Systems (33 CFR 183).

**CAUTION:** Always STOP engines before switching to "OFF" position. Erratic operation, particularly after very long periods of idleness, can be cleared by rapidly switching back and forth briskly several times without any load connected.

- NOTE:**
- (1) Locate switch to keep battery cables as short as possible.
  - (2) If switch is to be mounted in an area subject to corrosion, it is recommended that a liquid electrical coating be applied to the terminal connections.
  - (3) Mounting screw size #10 pan head or round head. Mount on a flat surface and do not over-tighten screws to prevent deforming the switch body.
  - (4) Protective skirt panels can be removed as required for cable positioning when installing the switch.
  - (5) Terminal stud size is 3/8 inch. Torque terminal nuts to 15 ft-lbs.

**OPTIONAL ACCESSORY**

Key Lock - Switch can be locked only in the "OFF" position. Key can be removed in either the locked or unlocked position.

The following diagram illustrates a typical installation.

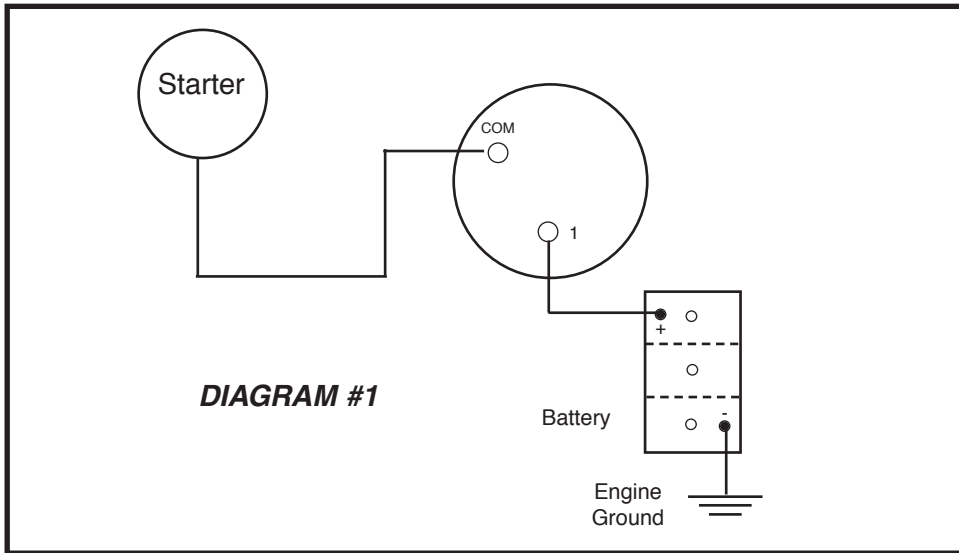

\* Above referenced standards can be obtained from:

- |   |  |  |
|---|--|--|
| 1. American Boat & Yacht Council, Inc.<br>613 Third Street, Suite 10<br>Annapolis, MD 21403 | 2. U.S. Coast Guard<br>Washington, D.C. 20593<br>(or your local C.G. office) | 3. N.F.P.A.<br>1 Batterymarch Park<br>Quincy, MA 02169 |
|---|--|--|

**BATTERY SWITCHES  
INSTALLATION AND OPERATING INSTRUCTIONS**

For use with alternators and generators rated 6-50 V.D.C.  
Switch rating: 315 amperes continuous, 450 amperes intermittent.

All wiring to the switch shall be performed by a QUALIFIED MARINE ELECTRICIAN, and in accordance with the "Fire Protection Standard For Motor Craft", N.F.P.A.\* No. 302, The Standards of the American Boat and Yacht Council, Inc.\*, and the U.S.C.G.\* Safety Standards for Boat Electrical Systems (33 CFR 183).

**CAUTION:** Always STOP engines before switching to "OFF" position. Erratic operation, particularly after very long periods of idleness, can be cleared by rapidly switching back and forth briskly several times without any load connected.

- NOTE:**
- (1) Locate switch to keep battery cables as short as possible.
  - (2) If switch is to be mounted in an area subject to corrosion, it is recommended that a liquid electrical coating be applied to the terminal connections.
  - (3) Mounting screw size #10 pan head or round head. Mount on a flat surface and do not over-tighten screws to prevent deforming the switch body.
  - (4) Protective skirt panels can be removed as required for cable positioning when installing the switch.
  - (5) Terminal stud size is 3/8 inch. Torque terminal nuts to 15 ft-lbs.

**OPTIONAL ACCESSORY**

Key Lock - Switch can be locked only in the "OFF" position. Key can be removed in either the locked or unlocked position.

The following diagram illustrates a typical installation.

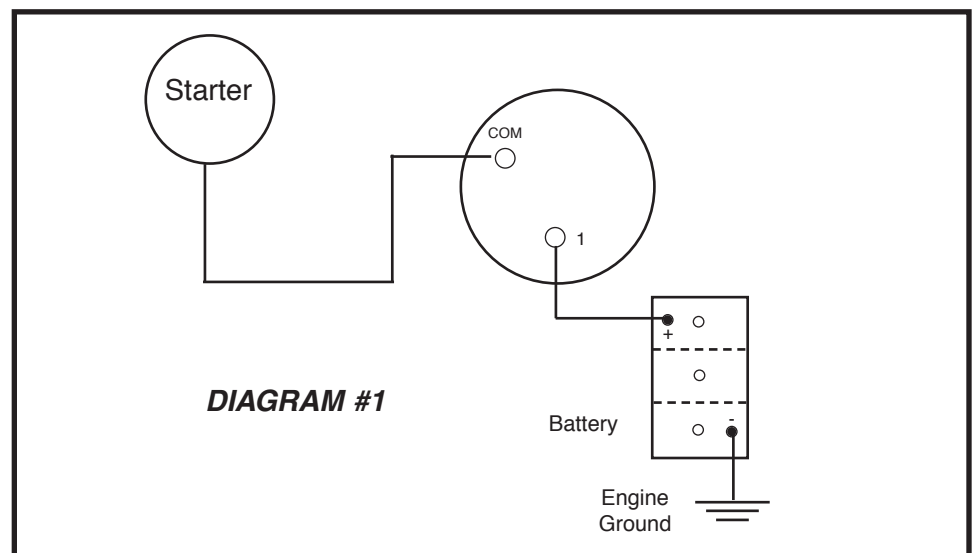

\* Above referenced standards can be obtained from:

- |   |  |  |
|---|--|--|
| 1. American Boat & Yacht Council, Inc.<br>613 Third Street, Suite 10<br>Annapolis, MD 21403 | 2. U.S. Coast Guard<br>Washington, D.C. 20593<br>(or your local C.G. office) | 3. N.F.P.A.<br>1 Batterymarch Park<br>Quincy, MA 02169 |
|---|--|--|