



a xylem brand

MANUAL MARINE TOILET

FEATURES

- Easy to clean white ceramic bowl
- Sturdy wood seat with durable baked enamel finish
- Forward angled pump for easy operation
- Convenient top-mounted dry bowl selector
- Reversible pump mounting for right or left hand installation
- External seal housing/rod guide for easy replacement
- Extra large seal housing allows piston rod assembly to be removed without removing valve cover
- Smooth external surfaces with skirted base to maintain cleanliness
- Base of pump and valve cover are skirted to conceal gasket/flap valves
- Triadic full-flow joker valve to avoid accidental blockage
- Multi-angle discharge port for versatility of plumbing connection

VARIATIONS AVAILABLE

MODEL NO.	DESCRIPTION
29090-2000	Compact Size Bowl & Seat

	WARNING Flood hazard. If toilet is installed below the waterline or may be below the waterline at any angle of heel or trim, it must be installed with properly positioned vented loops. Failure to do so can result in flooding which can cause loss of property and life.
--	--

29120-2000	Household Size Bowl & Seat
-------------------	----------------------------

SPECIFICATIONS

- Inlet port – 3/4"
- Discharge port – 1-1/2"
- Weight – compact bowl: 26 lb
large bowl: 32 lb

APPLICATION

The Jabsco Manual toilet is designed to meet the requirements of onboard marine applications. It may be installed above or below the waterline. If the toilet is, or can be, below the waterline at any normal (including static) attitude of vessel heel and/or trim, a 3/4" Vented Loop Fitting must be installed in a length of hose that connects the flushing pump to the rear of the bowl. The vented Loop Fitting should be positioned so it remains about eight inches or more above the waterline at all angles of heel and trim. If the toilet is plumbed to an overboard discharge, the



discharge hose must also include a Vented Loop Fitting. (See WARNING.) The toilet may be plumbed so waste is discharged to holding tank, directly overboard (where permitted by law) or into a certified waste treatment device. For installation versatility, the pump assembly may be positioned on the left or right hand side of the bowl. Its multi-angle discharge port will allow routing of discharge hose in almost any direction for ease of installation and neat appearance.

The toilet is available with either a compact china bowl to fit restrictive areas or a large bowl with household size seat assembly for maximum comfort. Its forward angled double action pump with convenient top mounted dry bowl selector is easy and natural to operate. It is self-priming with a dry suction lift of up to 3 feet (1 meter) and a discharge head to 9 feet (3 meters). A full-flow triadic joker valve resists blockage while providing positive back-flow prevention.

OPERATION

Manual Marine toilets have traditionally been somewhat cumbersome and confusing to operate and maintain. The Jabsco toilet has been designed with user convenience in mind. The pump assembly is angled forward to provide a natural, smooth stroke action. It has a top mounted wet/dry bowl selector which can be operated with the same hand used for pumping without releasing the pump handle.

The Jabsco toilet is surprisingly easy to operate. Simply move the wet/dry bowl selector to the wet bowl position (left) and pump handle up and down a few times to add some water to the bowl prior to use. After using, flush by again pumping handle up and down (in wet bowl position) until bowl is thoroughly rinsed and evacuated. Then move the wet/dry bowl selector to the dry bowl position (right) and continue pumping until only about one cup of water

remains in the bottom of bowl. Leave the wet/dry bowl selector in the dry bowl position when toilet is not in use.

Positioning and Mounting

The Jabsco Manual Toilet is assembled at the factory for operation with the right hand. If preferred, or required by available space, the pump and bowl may be rotated 180 degrees to provide left hand operation. To do this, remove hose from inlet elbow (back of bowl) and rotate elbow 180 degrees. It may be necessary to remove the elbow, loosen spud retaining nut and rotate the spud fitting so elbow will be tight when pointing in the opposite direction. Remove, rotate 180 degrees and reinstall both the bowl and pump assembly. Reconnect hose to inlet elbow and the toilet is ready for left hand operation.

The toilet must be installed on a well supported flat surface. Ideally, if underside of mounting surface is accessible, the toilet base should be through-bolted (using 5/16" bolts, washers and locknuts) to the mounting surface. If the underside of mounting surface is not accessible, the use of 5/16" lag bolts and washers is an acceptable alternative.

Before installing, position toilet in location to be installed. Ensure there is adequate space around toilet to easily operate pump and raise seat and lid to a fully opened position. Seat and lid should swing open at least 110 degrees and be supported when open to avoid strain on hinges. Ensure the base drain plug is accessible and inlet and discharge hoses can be attached to their respective ports without inducing significant lateral force. The discharge elbow may be rotated (by loosening two flange screws, rotating elbow and retightening screws) to accept the most convenient routing of the discharge hose.

When proper installation has been established mark the four base mounting holes on mounting surface and remove toilet. Ensure that no wiring or plumbing is positioned under the mounting surface which may be accidentally damaged when the surface is drilled. Drill appropriate size holes for fasteners being used. Mount toilet using flat washers between head of bolts and plastic toilet base. If desired a small bead of silicone or latex sealant may be applied around base where it contacts the mounting surface to prevent moisture from getting under the toilet base.

NOTICE: Do not use Polysulfide base sealants because they may chemically attack the plastic which can result in breakage.





Plumbing

Do not plumb the toilet to vessel's potable water supply. To do so can cause water contamination that can cause illness or death.



If installing a new inlet thru-hull/seacock, ensure that it is positioned on a part of the hull which is wetted at all angles of heel or trim and free of water turbulence at any hull speed. If discharging waste overboard (check legal restrictions for overboard discharge), ensure discharge thru-hull/seacock is both aft of and higher than the inlet thru-hull/seacock. All inlet plumbing should be a

minimum of 3/4" ID and discharge plumbing a minimum of 1-1/2" ID. All hose ends should be double clamped with stainless steel hose clamps. If the toilet is above waterline route hoses to seacocks, holding tank or treatment device via a route as direct as possible. However, for maximum sealing effect on the discharge joker valve, it is recommended that the discharge hose is looped upward about 8" above the discharge elbow before it descends to its termination point. All bends and elbows in plumbing should be kept to a minimum. It

	WARNING
	Flood hazard. If toilet is installed below the waterline or may be below the waterline at any angle of heel or trim, it must be installed with properly positioned vented loops. Failure to do so can result in flooding which can cause loss of property and life.

should not be necessary to use any sealing compound when attaching hoses to the inlet or discharge ports.

If the toilet is, or can be, below the waterline, at any normal (including static) attitude of vessel heel and/or trim, a 3/4" vented loop must be installed in a length of hose connecting the flushing pump to the rear of the bowl. The vented loop fitting must be positioned 8" above the waterline at all angles of heel and trim. To accomplish this, remove the 3/4" hose supplied with toilet and replace with a new length of hose long enough to properly position the vented loop. If the toilet is plumbed for overboard discharge, a 1-1/2" vented loop must be installed in the discharge hose. The waste vented loop fitting must also be positioned 8" above the waterline at all

	WARNINGa
	Flood hazard. Close inlet and outlet seacocks a prior to disassembling toilet. Failure to do so can result in flooding which can cause loss of a property and life.a

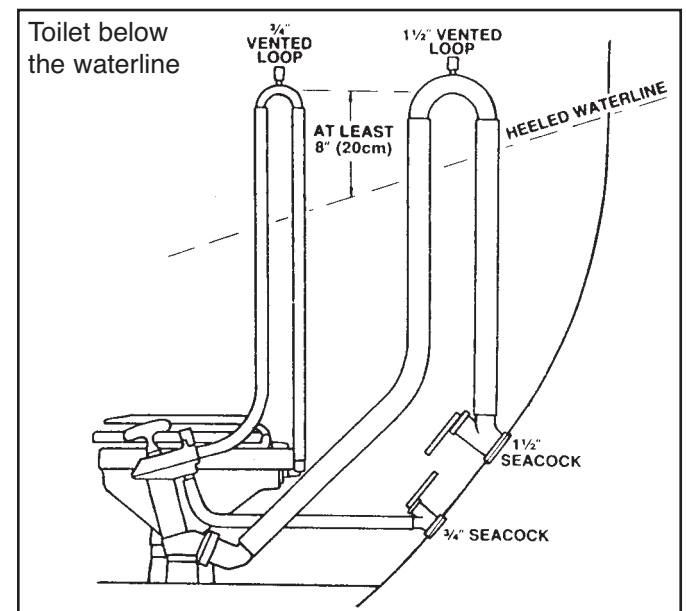

angles of heel and/or trim and ideally should be located as close to the toilet as practical. (See WARNING.)

If unfamiliar with proper plumbing requirements for

marine toilets, it is recommended that a qualified marine plumbing technician is contacted to do the installation.

Maintenance

Periodic maintenance is generally not required other than periodic cleaning and lubricating with Rule® brand toilet cleaner and conditioner. To winterize toilet, operate the pump in the dry bowl mode to evacuate as much water as possible. Drain the remaining water from the base by removing the base plug or sponge from bottom of bowl. If charging the holding tank with anti-freeze by pumping it through the toilet, use only ethylene glycol based anti-freeze. To use petroleum based anti-freeze can cause damage to the internal rubber toilet parts.

Service

Before performing any service, flush the toilet long enough to ensure all waste is flushed from the discharge hose. Close both inlet and discharge (if applicable) seacocks and put a "DO NOT OPEN" notice on each to guard against accidental opening and flooding while service is being performed.

SEAL REPLACEMENT - Lift handle and wrap rod with one turn of tape just under the handle. Gently grasp piston rod (on tape) with pliers and unscrew handle. **HOLD PISTON ROD AT ALL TIMES OR IT MAY DROP DOWN INTO PUMP.** Remove bumper washer and unscrew and remove seal/rod guide assembly. Wrap threads of piston rod with one turn of tape to protect new seal and install new seal/rod guide assembly. Remove tape from threads and reinstall bumper washer and handle. Tighten handle snugly (do not overtighten) and remove remaining tape.

MAJOR OVERHAUL - Loosen hose clamps on inlet hose and remove it from the pump. Remove bowl link hose from rear of pump assembly. Remove the two screws that secure the discharge flange and elbow. Remove the four screws that secure the pump to the base and remove pump assembly.

The discharge joker valve and base valve/gasket can now be removed. Remove the six screws that secure the top valve cover, move the wet/dry bowl selector to the wet bowl position and remove valve cover and piston rod assembly from pump cylinder, taking care not to lose the flap valve seating spring on the underside of the cover. Remove top valve/gasket assembly and valve seat. Remove piston O-Ring and seal/rod guide assembly (see Seal Replacement instructions.). Clean all parts and inspect for damage. Ensure pump cylinder wall is not badly grooved or worn.

Install new seal/rod guide assembly (see Seal Replacement instructions). Install new piston O-Ring. Lubricate bore of pump cylinder with petroleum jelly. Position valve seat and top valve/gasket assembly on top of cylinder. Ensure the flap valve seating spring is pushed securely on its locator post on the underside of the valve cover. With the wet/dry bowl selector in the wet bowl position, insert piston into cylinder bore and position

valve cover on top of cylinder. Secure with six screws. Install joker valve in discharge elbow and base valve/gasket assembly on base. Position discharge flange and elbow on pump and secure with two screws. Position pump assembly on base and secure with four screws. Reattach bowl link hose to pump. Reattach inlet hose to pump and secure with clamps.

BOWL SEAL REPLACEMENT - To replace the bowl seal (base O-Ring) disconnect inlet and discharge hoses and remove toilet from its mounting surface. Pry nut caps from bowl fasteners. Invert toilet and hold bolts on underside of base while removing nuts and washers. Lift base from bowl and remove O-Ring. Install new O-Ring, position base on bowl and secure with fasteners ensuring plastic washers are sandwiched between S. S. flat washers and ceramic bowl. Invert toilet and snap plastic nut caps onto nuts. Reinstall toilet on mounting surface, connect hoses and secure with hose clamps.

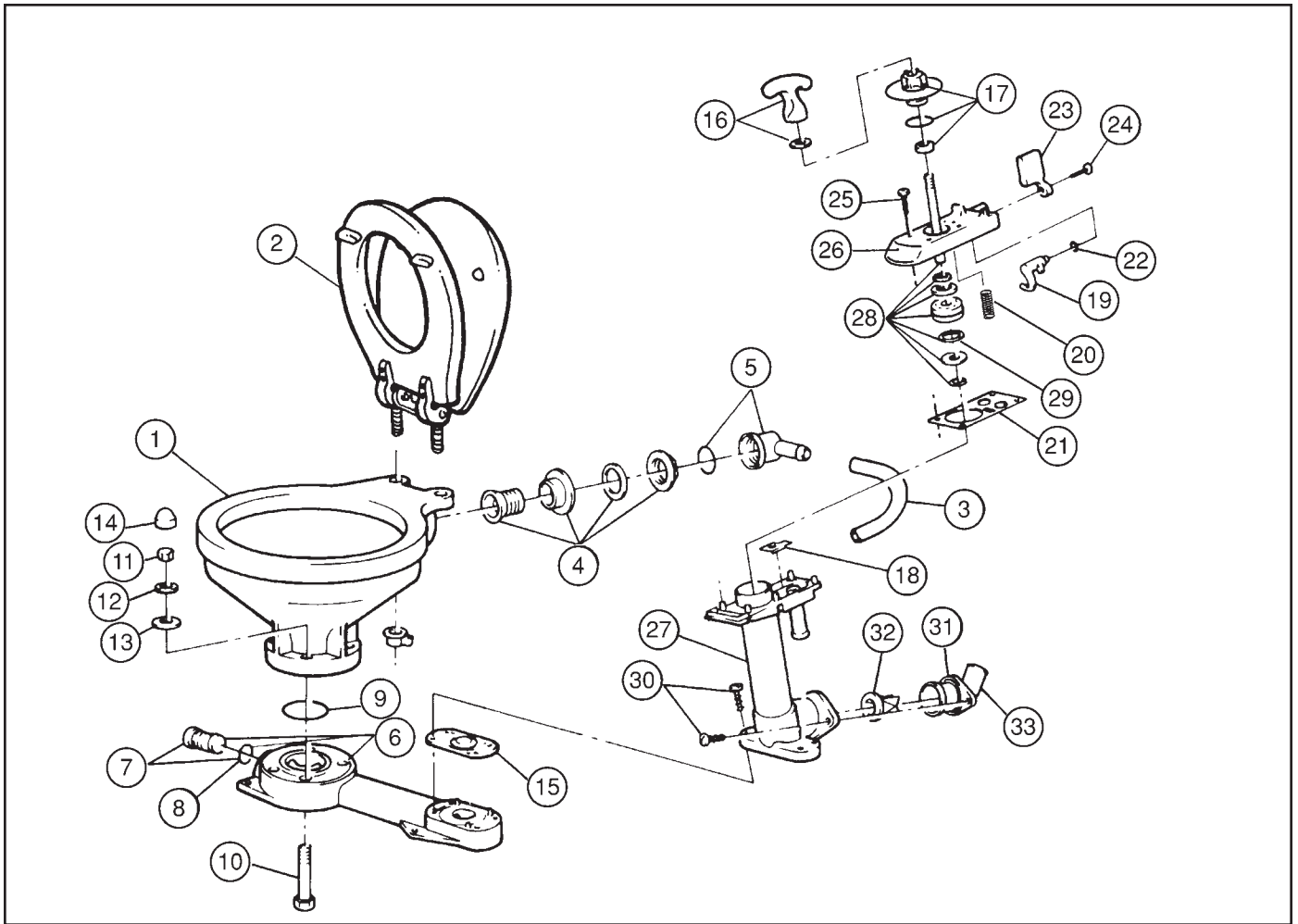

REPAIR KITS AVAILABLE

- A 29045-2000 MAJOR SERVICE KIT, PUMP
- B 29040-2000 PUMP ASSEMBLY
- C 29094-2000 VALVE COVER & HANDLE ASSEMBLY
- D 29051-2000 PUMP CYLINDER ASSEMBLY
- E 29047-0000 BOWL INSTALLATION KIT

PARTS LIST

Key	Description	Qty. per Toilet	Part Number	Qty per Repair Kit					
				A	B	C	D	E	
1	BOWL								
	COMPACT	1	59127-7002						
	LARGE	1	18753-0060						
2	SEAT, LID & HINGE SET								
	COMPACT	1	29097-1000						
	LARGE	1	29127-1000						
2A	HINGE KIT-COMPACT	1	18753-0181						
3	HOSE								
	COMPACT	1	29035-0000						
	LARGE	1	29035-0001						
4 & 5	BOWL SPUD AND INTAKE	1	29048-0000						
6	ELBOW & O-RING BASE, PLUG & O-RING ASSY	1	29041-1000						
7	PLUG & O-RING ASSY	1	29028-1000						
8	O-RING (PLUG)	1			1				
9	O-RING (BOWL)	1	44101-1000						1
10	BOLT	4							4
11	NUT	4							4
12	WASHER (SS)	4							4
13	WASHER (NYLON)	4							4
14	CAP	4			2				4
15	BASE VALVE GASKET	1	29043-0000	1	1				
16	HANDLE						1		

Key	Description	Qty. per Toilet	Part Number	1 1 Qty per Repair Kit					
				A	B	C	D	E	
	WITH BUMPER WASHER								
17	SEAL ASSEMBLY *	1	29044-2000	1	1	1			
18	TOP VALVE SEAT	1		1	1		1		
19	CAM			1				1	1
20	FLAP VALVE	1			1	1			
	SEATING SPRING								
21	TOP VALVE GASKET	1	29042-0000	1	1				
22	O-RING (FLUSH LEVER)	1		1	1	1			
23	FLUSH CONTROL LEVER	1			1	1			
24	SCREW (FLUSH LEVER)	1		1	1	1			
25	SCREW (VALVE COVER)	6		1	6	6			
26	VALVE COVER	1			1	1			
27	PUMP CYLINDER	1			1			1	
28	PISTON, ROD & O-RING ASSY	1	29046-0000		1				
29	O-RING (PISTON)	1	29017-1000	1					
30	SCREW (PUMP CYLINDER)	6		1	2		2		
31	DISCHARGE FLANGE	1	29091-0000		1		1		
32	JOKER VALVE	1	29092-0000	1	1		1		

DIMENSIONAL DRAWING

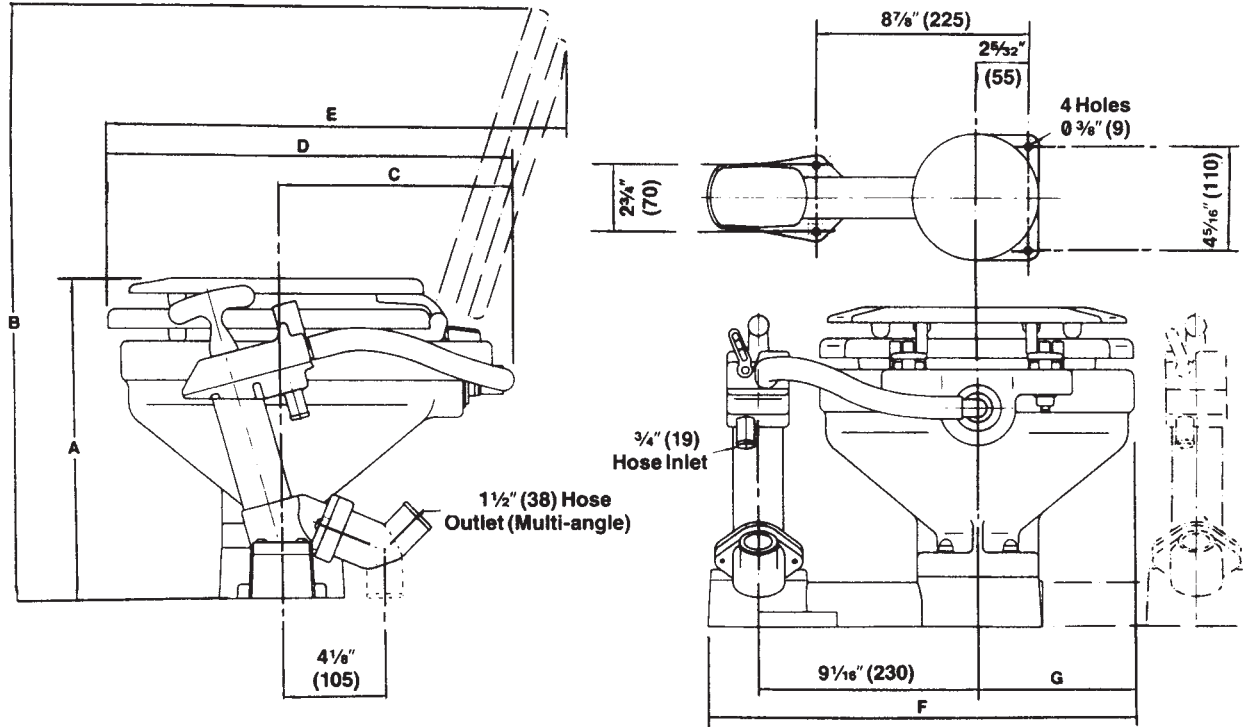

		A	B	C	D	E	F	G
29090-2000	MANUAL TOILET STANDARD BOWL	13 ³ / ₁₆ (335)	24 ¹ / ₄ (615)	9 ³ / ₄ (247)	16 ³ / ₄ (425)	19 ¹ / ₈ (485)	17 ³ / ₄ (450)	6 ¹ / ₂ (165)
29120-2000	MANUAL TOILET LARGE BOWL	13 ⁵ / ₈ (345)	27 ⁵ / ₈ (700)	11 (280)	19 ⁵ / ₁₆ (490)	22 ⁷ / ₈ (580)	18 ⁵ / ₁₆ (465)	7 ¹ / ₈ (180)

THE PRODUCTS DESCRIBED HEREIN ARE SUBJECT TO THE JABSCO ONE YEAR LIMITED WARRANTY, WHICH IS AVAILABLE FOR YOUR INSPECTION UPON REQUEST.

www.xylemflowcontrol.com

Jabco, 100 Cummings Center, Ste. 535-N, Beverly, MA 01915
Tel: +1 978 281 0440 Fax: +1 978 283 2619

Jabco, Bingley Road, Hoddesdon, Hertfordshire, EN11 0BU
Tel: +44 (0) 1992 450 145 Fax: +44 (0) 1992 467 132

NHK Jabco Co Ltd, 3-21-10, Shin - Yokohama Kohoku-ku, Yokohama 222
Tel: +81 (0) 45 475 8906 Fax: +81 (0) 45 475 8908

Jabco GmbH, Oststraße 28, 22844 Norderstedt
Tel: +49 (0) 40 53 53 73 0 Fax: +49 (0) 49 53 53 73 11

Jabco Italia, s.r.l., Via Tommaso, 6, 20059 Vimercate, Milano
Tel: +39 039 685 2323 Fax: +39 039 666 307

USA

UK

JAPAN

GERMANY

ITALY



a xylem brand